

Exclusive Turnkey Solution

for Autonomous Construction Data Collection

The alliance with Boston Dynamics permits Trimble® exclusivity to sell and support the Spot robot with integrated Trimble solutions for 3D laser scanning, robotic total stations, and GNSS technologies for the building construction and civil construction markets. This turnkey solution will streamline the operation of the Trimble payloads and the Spot robot platform to provide virtual design and construction teams a clear picture of jobsite progress on an ongoing basis through autonomous construction data collection workflows. Trimble technologies integrated with Spot enable accurate, scalable and rapid data acquisition while Trimble's construction collaboration platforms provide a continuous flow of information between field and office.

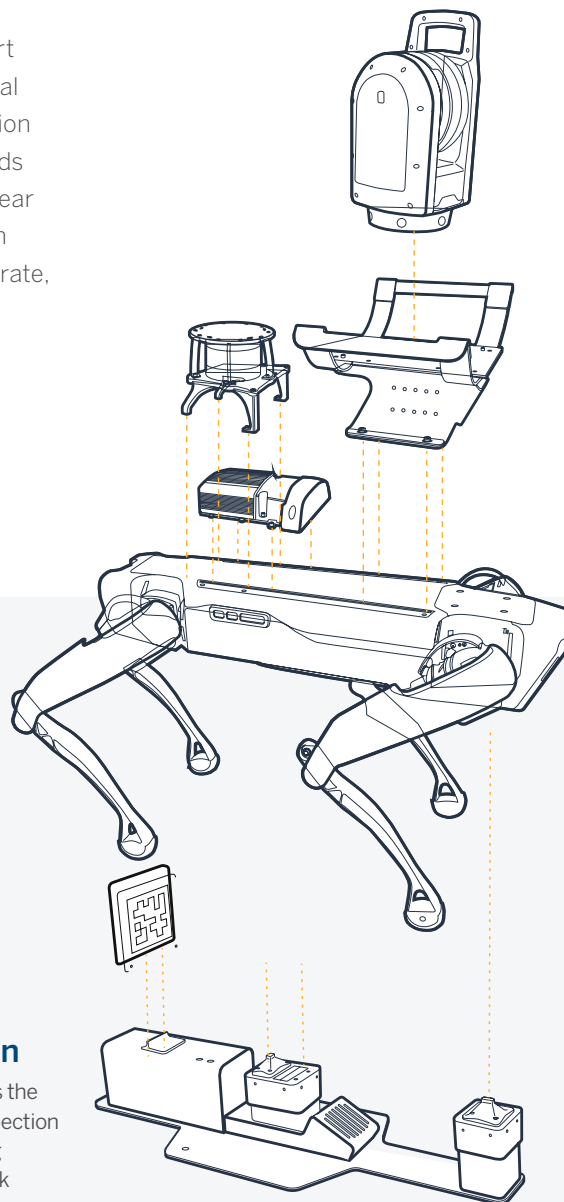
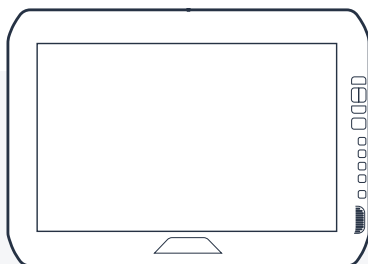
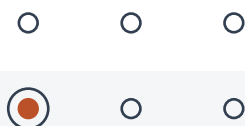

Autonomous Scanning Operation

Collect consistent and reliable data for improved production and quality control monitoring. Document change and perform design validation to ensure the as-built condition matches the as-designed intent.

Safe Scanning, Continuously

Send Spot and the Trimble X7 3D laser scanner into unsafe conditions to perform dirty, dull, or dangerous tasks. Improve job site safety and address labor shortages.

Automated Scan Registration in the Field

In-field registration with Trimble FieldLink software ensures the right data is captured the first time. Perform real-time design validation workflows such as scan-to-model comparisons and surface analysis inspections to make immediate decisions in the field without leaving the job site.

Integrated Docking Station

A self-charging station for Spot transforms the robot into a truly autonomous remote inspection tool. Utilize multiple docks to facilitate long missions on remote sites. With built-in dock detection, Spot will automatically recognize where to dock to charge Spot and the X7 laser scanner.

Scan Data Upload

A built-in Gigabit Ethernet connection in the docking station enables the fast offload of registered scan data from the X7 laser scanner. Immediately access scan data at the end of a mission or post to a cloud sharing platform to perform design validation analysis.

Integrated Ruggedized Tablet

A ruggedized Trimble tablet allows you to control Spot and the X7 laser scanner through one device. Use the tablet to define a mission for Spot, set scanning parameters for the X7, perform in-field registration, design validation, and access Trimble Connect for project communication and collaboration tools.





Exclusive Turnkey Solution

for Autonomous Construction Data Collection



Real-time, as-built data analysis

The initial integration of Trimble technology with Spot is focused on the use of Trimble 3D capture technology. A predefined path of waypoints can be created directing the Spot robot to collect laser scans. These 'data collection missions' increase efficiency when scheduled to run regularly for continuous design validation and immediate progress reporting.

Continuous data capture while operating autonomously

Laser scans can be tied to a project coordinate system, collected, and then made into a composite point cloud in real-time on the Trimble tablet controller before leaving the site. A self-charging docking station enables the in-field charging of batteries on both Spot and the X7 3D laser scanner, and the Gigabit Ethernet connection provides continuous data transfer while performing autonomous operations.

Technical information

Included in the turnkey package:

- Boston Dynamics Spot Enterprise robot
- Spot Dock
- Spot Enhanced Autonomy Package (Spot EAP)
 - Velodyne LiDAR Puck
 - Boston Dynamics Spot CORE
- Spot Defender
- Trimble X7 3D Laser Scanner Kit
- Trimble FieldLink software with Robotics Module
- Trimble ruggedized tablet controller